

**SPure™ H₂O / HC Filters
with Compression Fittings**

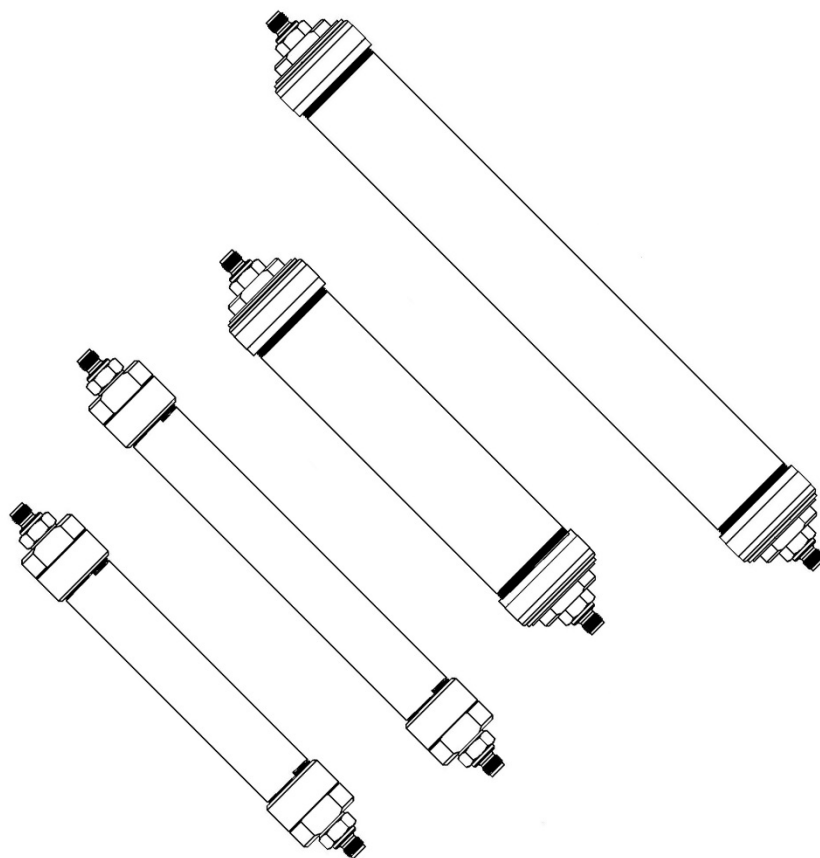



Warnings

Warnings must be read carefully and understood. Improper use of this product can cause harm or death to personnel and damage to property!



Wear eye protection and use caution when working with pressurized systems.

Maximum pressure rating for SPure H₂O / HC Filters: 6.9 bar / 100 psi.

When using a high-pressure gas source overpressure protection must be provided.

Do not use with supply gas H₂O concentration greater than 0.1%. Contains molecular sieve which may become very hot in contact with liquid water. Do not use with liquids.

Do not expose the protective outer plastic tube to solvents.

Not for use with hydrogen or hazardous gases.
Consult local regulations and your company's safety procedures.

Product Numbers

Size	1/8" Brass	1/4" Brass	1/8" SS	1/4" SS	Maximum Pressure
88 cc	202324-B	202325-B	202324-SS	202325-SS	6.9 bar / 100 psi
116 cc	202324L-B	202325L-B	202324L-SS	202325L-SS	6.9 bar / 100 psi
240 cc	202324D-B	202325D-B	202324D-SS	202325D-SS	6.9 bar / 100 psi
400 cc	202324XL-B	202325XL-B	202324XL-SS	202325XL-SS	6.9 bar / 100 psi

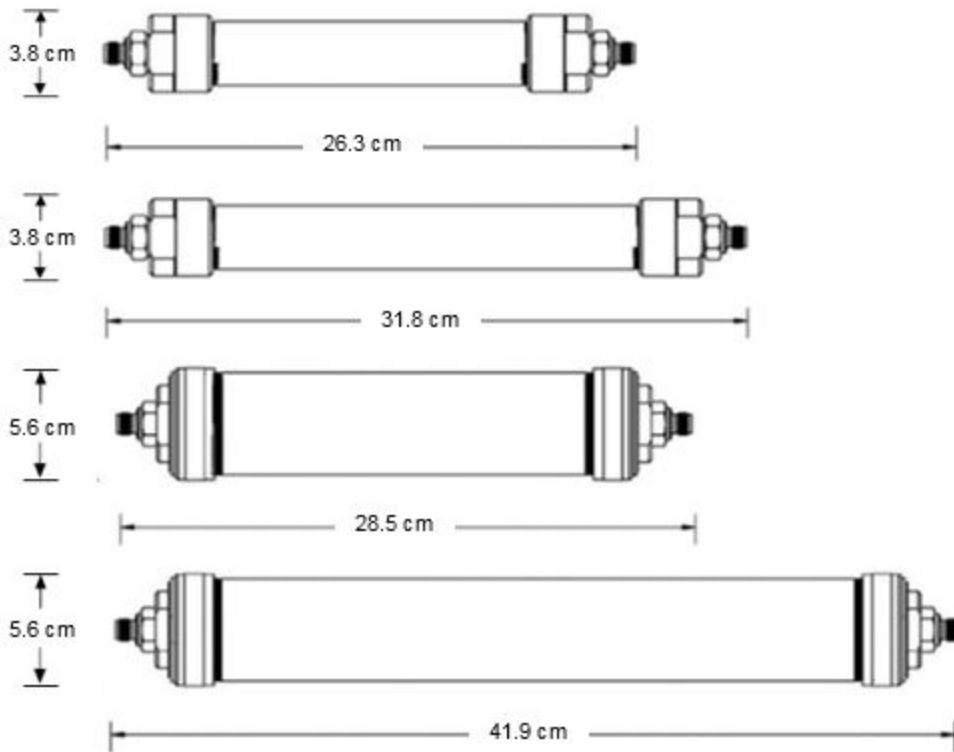

From top to bottom: 88 cc, 116 cc, 240 cc, 400 cc.

Filter Setup and Use

Installation for Compression Fittings

1. Check the package contents for damage. Contact your supplier if any items are damaged or missing.
2. The SPure Filter is delivered in the active state, filled with helium. It is ready for use, but it is recommended that the trap be purged with the gas to be purified.
3. For the best connections, start with freshly-cut tubing in the gas line. 1/8" nuts should be turned 3/4 turn past finger tight. 1/4" nuts should be turned 1-1/4 turns past finger tight.
4. To connect in-line, first purge the gas line with the supply gas. While maintaining a low purge rate of 10 to 30 cc/min, remove the end plugs from both ends of the trap, then attach the inlet end of the trap to the gas line.
5. While the end plugs are removed from the trap during installation, a small amount of air will diffuse into the adsorbent. As long as the trap is attached to the gas line within a few minutes, the loss of adsorbing capacity will be negligible.
6. Attach the outlet end of the trap.
7. Purge the entire system until a total of 1 to 2 liters of gas has been flushed through.
8. Leak check all connections.

Chromatography Research Supplies, Inc.
2601 Technology Drive
Louisville, KY 40299
USA

tel. (+1) 502-491-6300

www.ChromRes.com



Recycling

Please contact CRS for information regarding recycling and reconditioning gas purifier products.