

**SPure™ H<sub>2</sub>O / HC Filters  
with Push-to-Connect Fittings**

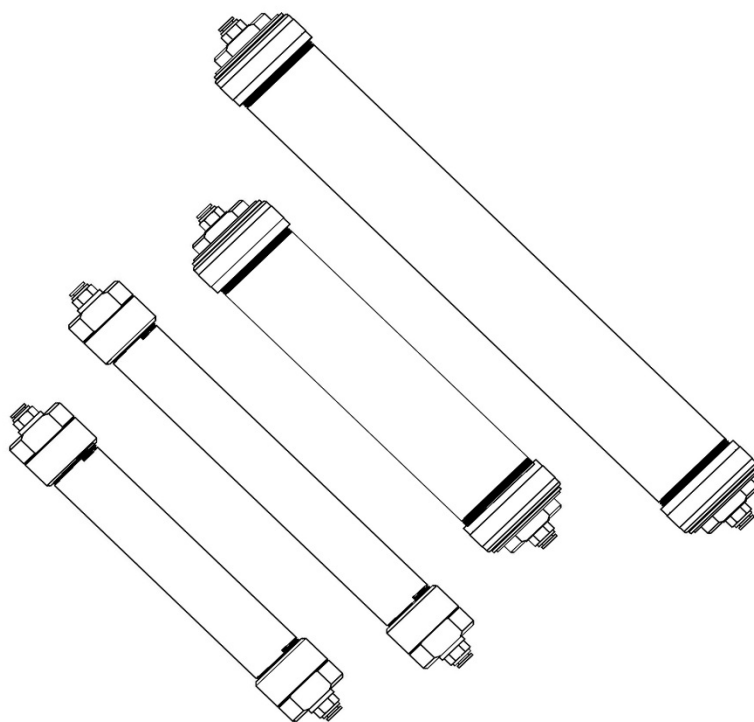



## Warnings

Warnings must be read carefully and understood. Improper use of this product can cause harm or death to personnel and damage to property!



Wear eye protection and use caution when working with pressurized systems.

Maximum pressure rating for SPure H<sub>2</sub>O / HC Filters: 6.9 bar / 100 psi.

When using a high-pressure gas source overpressure protection must be provided.

Do not use with supply gas H<sub>2</sub>O concentration greater than 0.1%. Contains molecular sieve which may become very hot in contact with liquid water. Do not use with liquids.

Do not expose the protective outer plastic tube to solvents.

Not for use with hydrogen or hazardous gases.  
Consult local regulations and your company's safety procedures.

### Product Numbers

Size	For 1/4" Tubing	For 6mm Tubing	Maximum Pressure
88 cc	202324-4-PC	202324-6-PC	6.9 bar / 100 psi
116 cc	202324L-4-PC	202324L-6-PC	6.9 bar / 100 psi
240 cc	202324D-4-PC	202324D-6-PC	6.9 bar / 100 psi
400 cc	202324XL-4-PC	202324XL-6-PC	6.9 bar / 100 psi

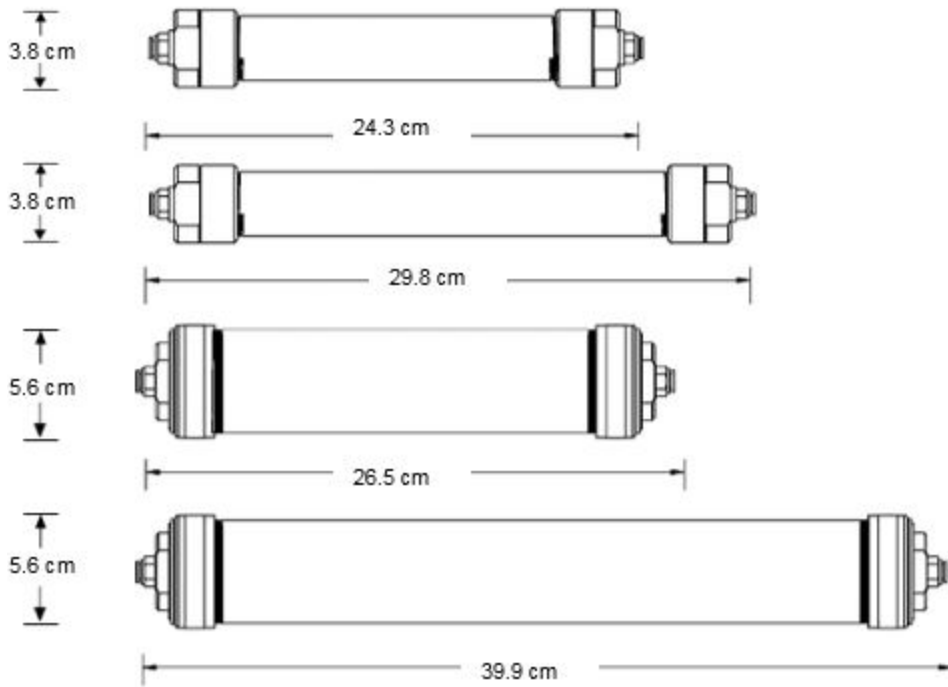

*From top to bottom: 88 cc, 116 cc, 240 cc, 400 cc.*

## Filter Setup and Use

### Installation for Push-to-Connect Fittings

1. Check the package contents for damage. Contact your supplier if any items are damaged or missing.
2. The SPure Filter is delivered in the active state, filled with helium. It is ready for use, but it is recommended that the trap be purged with the gas to be purified.
3. Make sure the ends of the plastic tubing are clean and free of scratches. If it is damaged, simply cut a small piece off the end.
4. Remove the shipping plug from the inlet end of the trap by depressing the locking tab and pulling on the plug.
5. Insert the tube into the fitting until it bottoms out. Make sure the tube is fully inserted.
6. Gently pull back on the tube to make sure the locking tab is engaged.
7. Repeat for the outlet end of the trap.
8. Purge the entire system until a total of 1 to 2 liters of gas has been flushed through. Maintain a low purge rate of 10 to 30 cc/min
9. Leak check all connections.
10. If leaks are present, remove the tube by pressing down on the locking tab, and simultaneously pulling up on the tube. Trim the end of the tube and re-insert.

Chromatography Research Supplies, Inc.  
2601 Technology Drive  
Louisville, KY 40299  
USA

tel. (+1) 502-491-6300

[www.ChromRes.com](http://www.ChromRes.com)



## **Recycling**

Please contact CRS for information regarding recycling and reconditioning gas purifier products.